

ECONOFLUSH_{AIR}

IN-WALL CISTERN
PNEUMATIC OPERATION

CODE:
J2982A

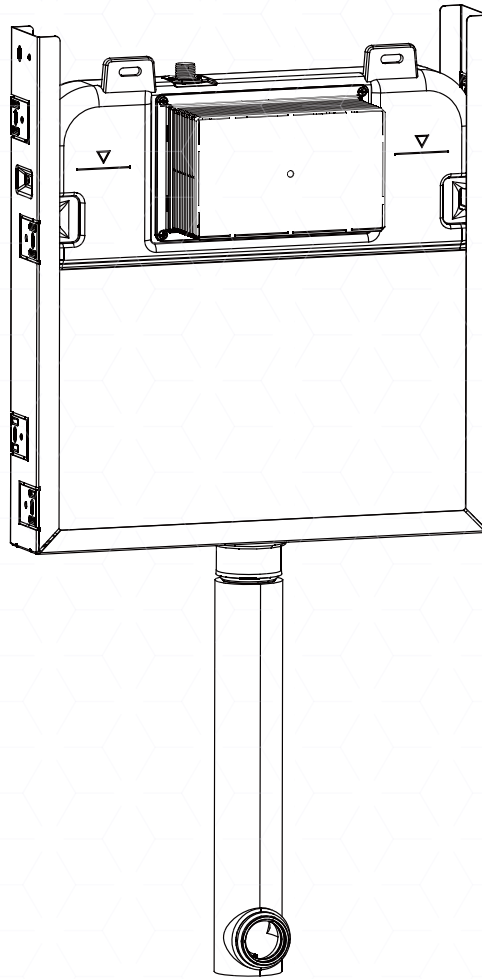

INSTALLATION
INSTRUCTIONS

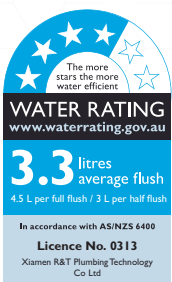

CISTERN COMPONENTS

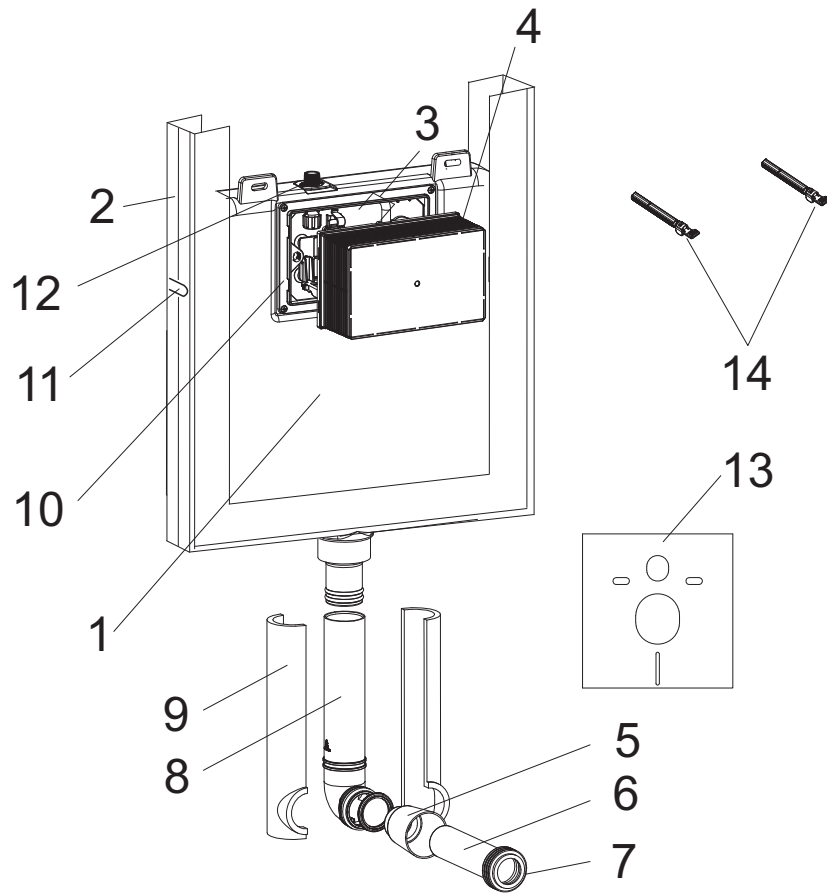

Code: J2982A

Main item list:

No.	Description	Qty
1	Cistern body	1
2	Metal frame	1
3	Pneumatic hoses	2
3	Actuator box	1
5	Pipe plug	1
6	Horizontal flush pipe	1
7	Kee seal	1
8	Vertical flush pipe	1
9	Flush pipe insulation	1
10	Actuator box bracket	1
11	Fixing tab (bent off frame)	2
12	Water inlet and isolating valve	1
13	Pan mounting pad	1
14	Locking pins	2

1. General dimensions and water supply

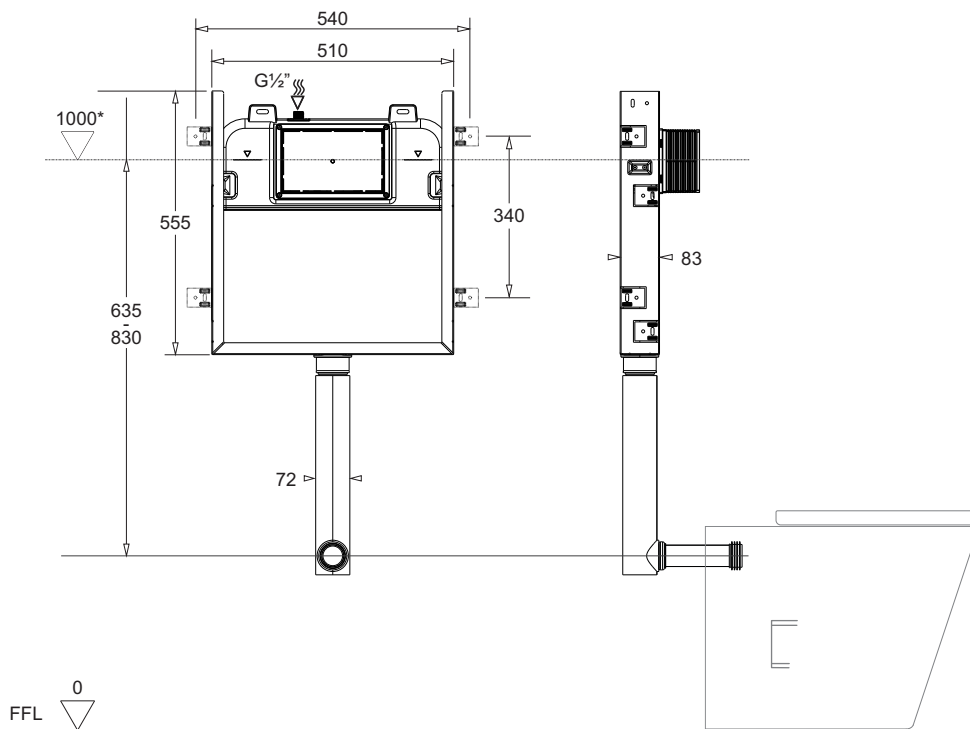

* Recommended

2. Cistern stud wall mounting diagram

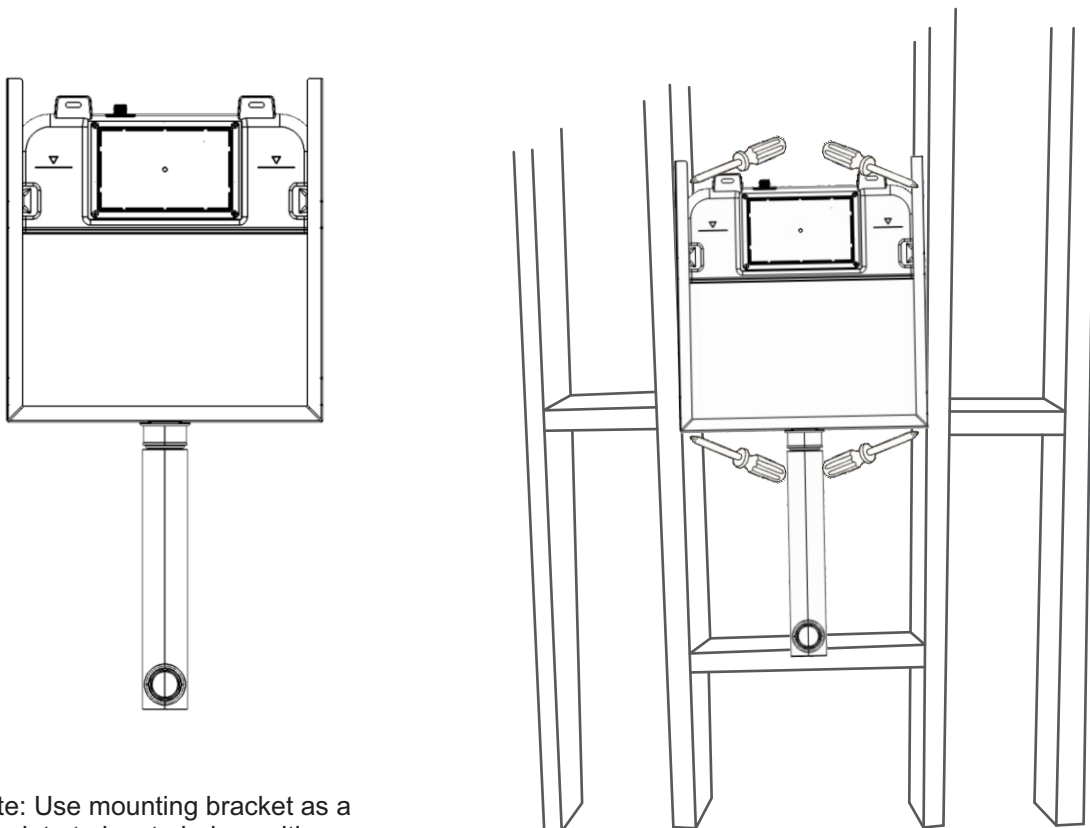

Note: Use mounting bracket as a template to locate hole positions

3. Cut and install flush pipe

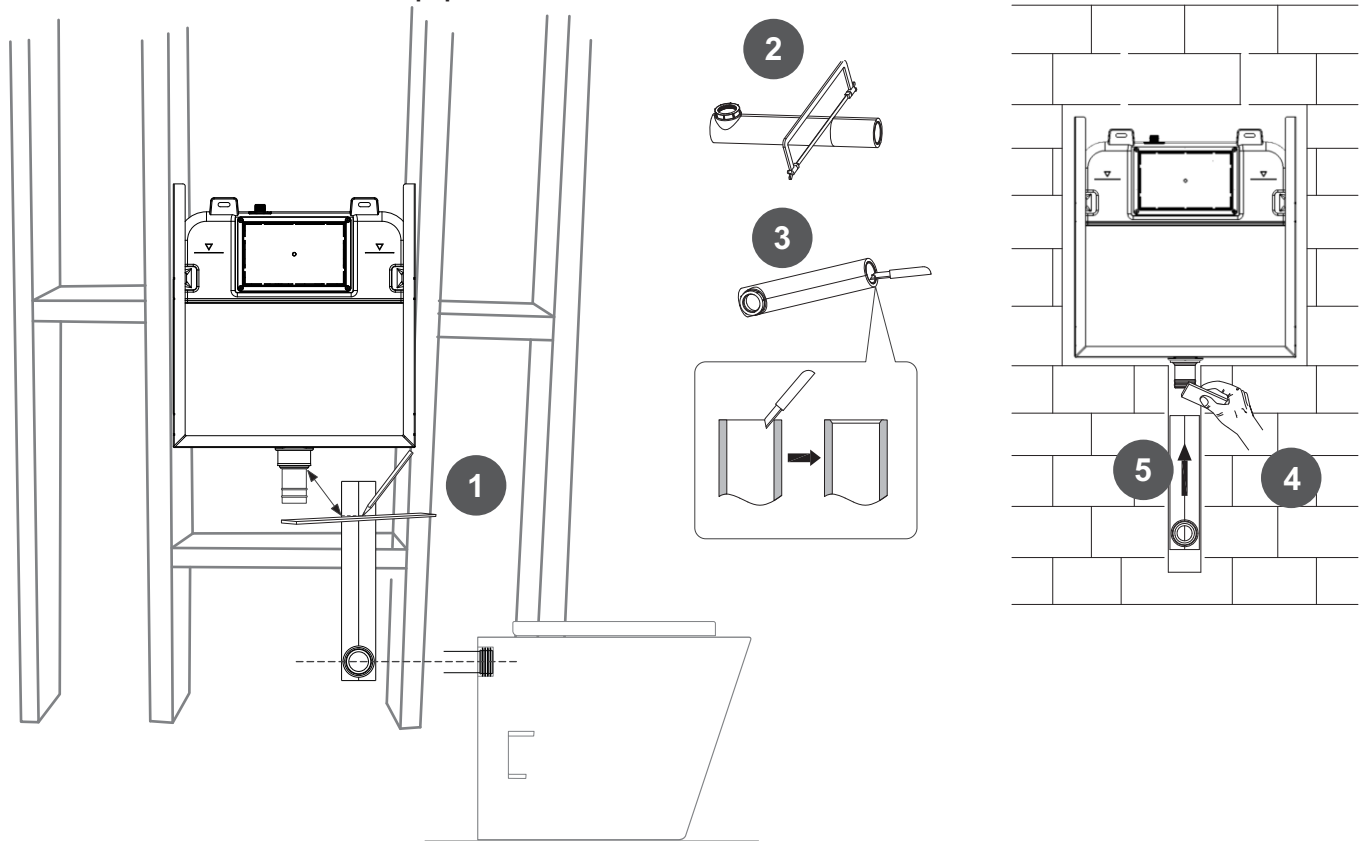

4. Determine the position of the pneumatic actuator

A. Flush buttons may be installed directly onto the cistern

B. Flush buttons may be also be installed remotely

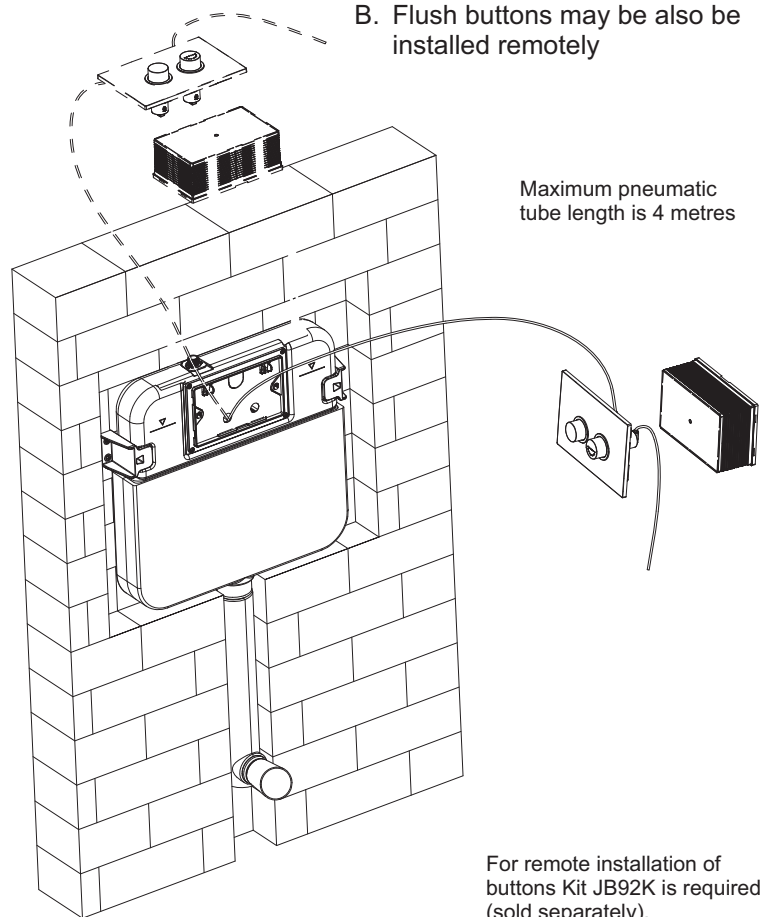
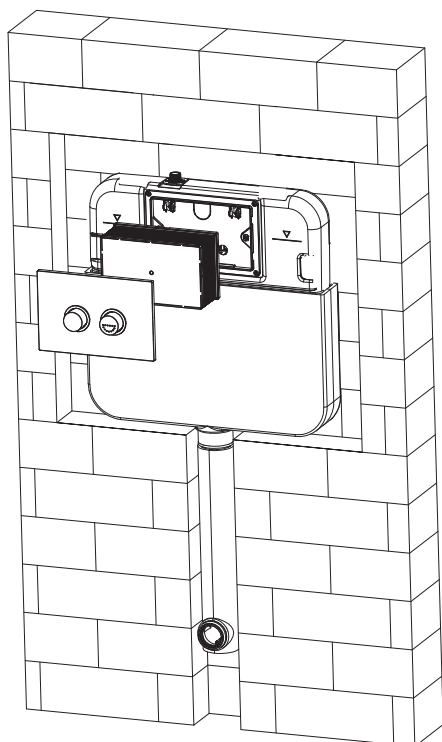

5. Install the actuator box and the pneumatic tube:

1. Pneumatic actuator installed on the front of the cistern.

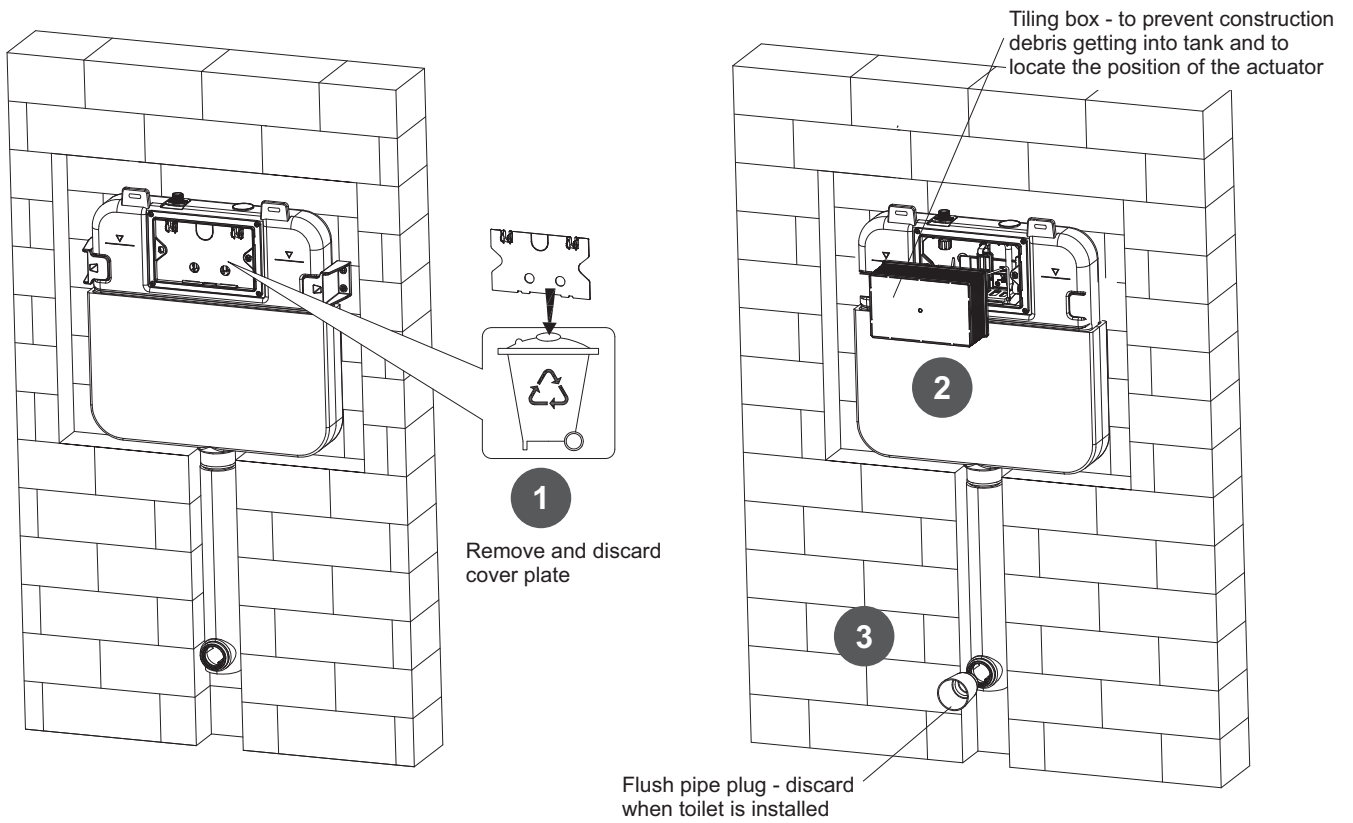

2. Pneumatic actuator installed in a remote position (refer also to instructions provided with kit JB92K).

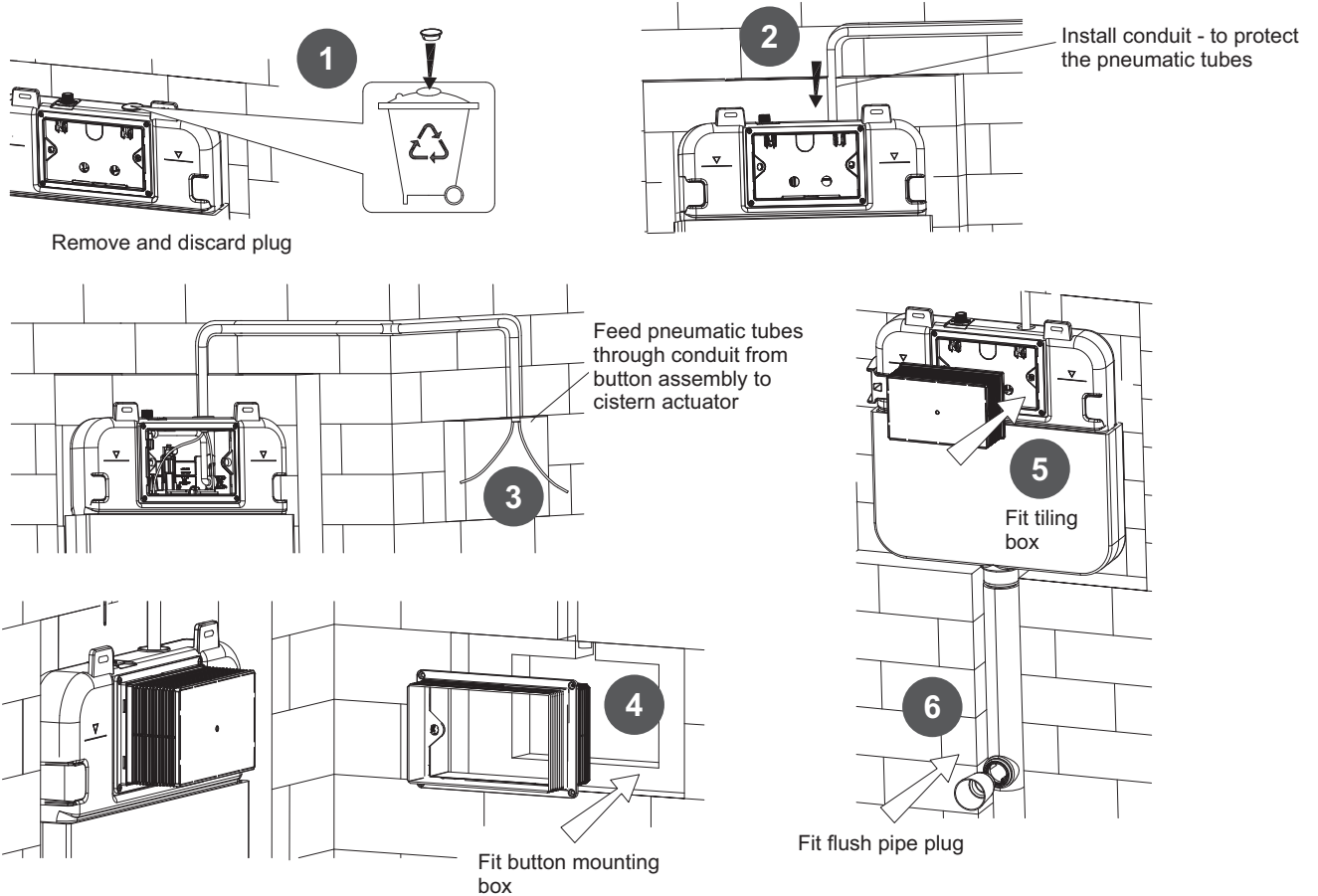

6. Wall thickness - 20-60mm from mounting face to finished wall face

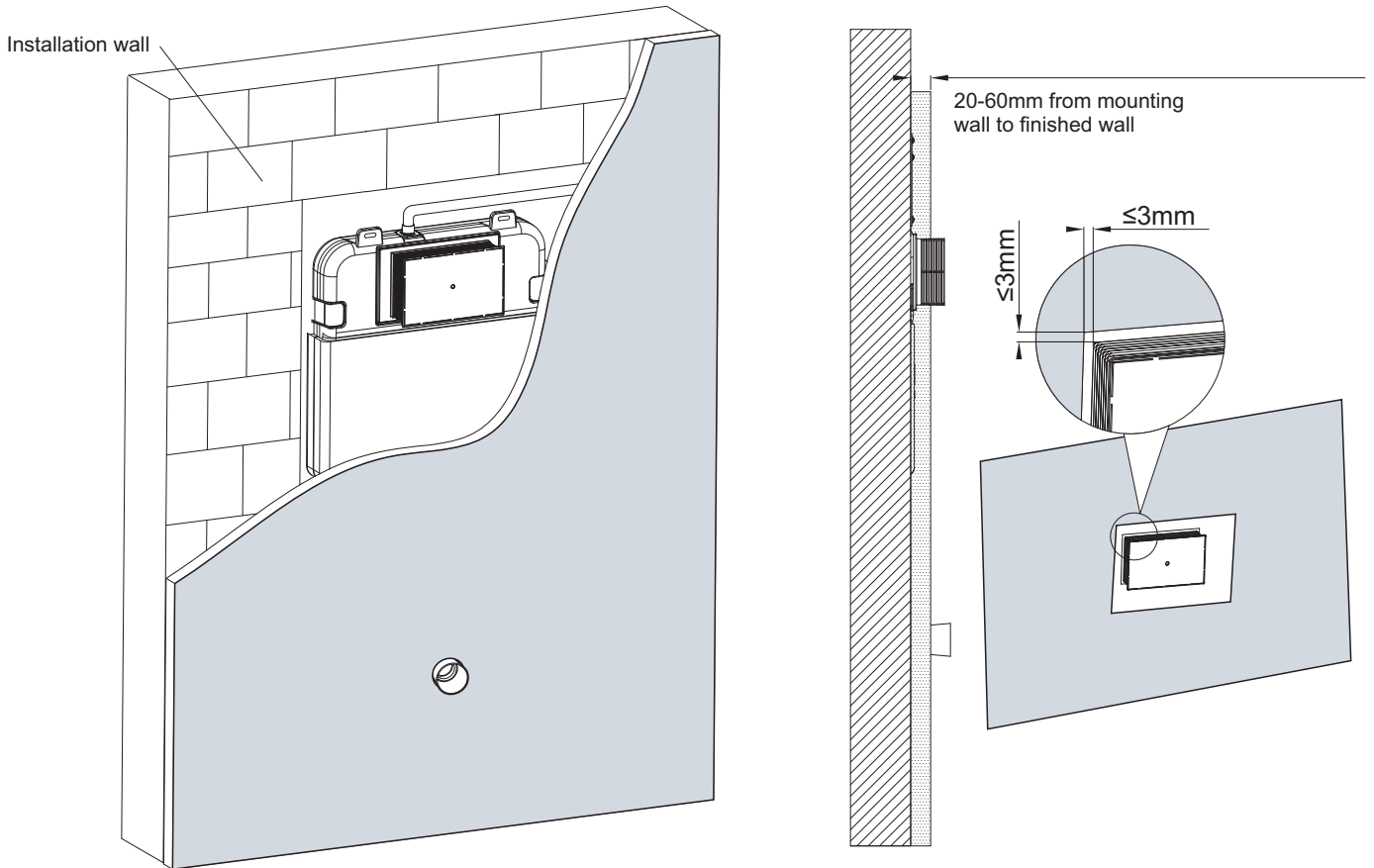

7. Installation of horizontal flush pipe

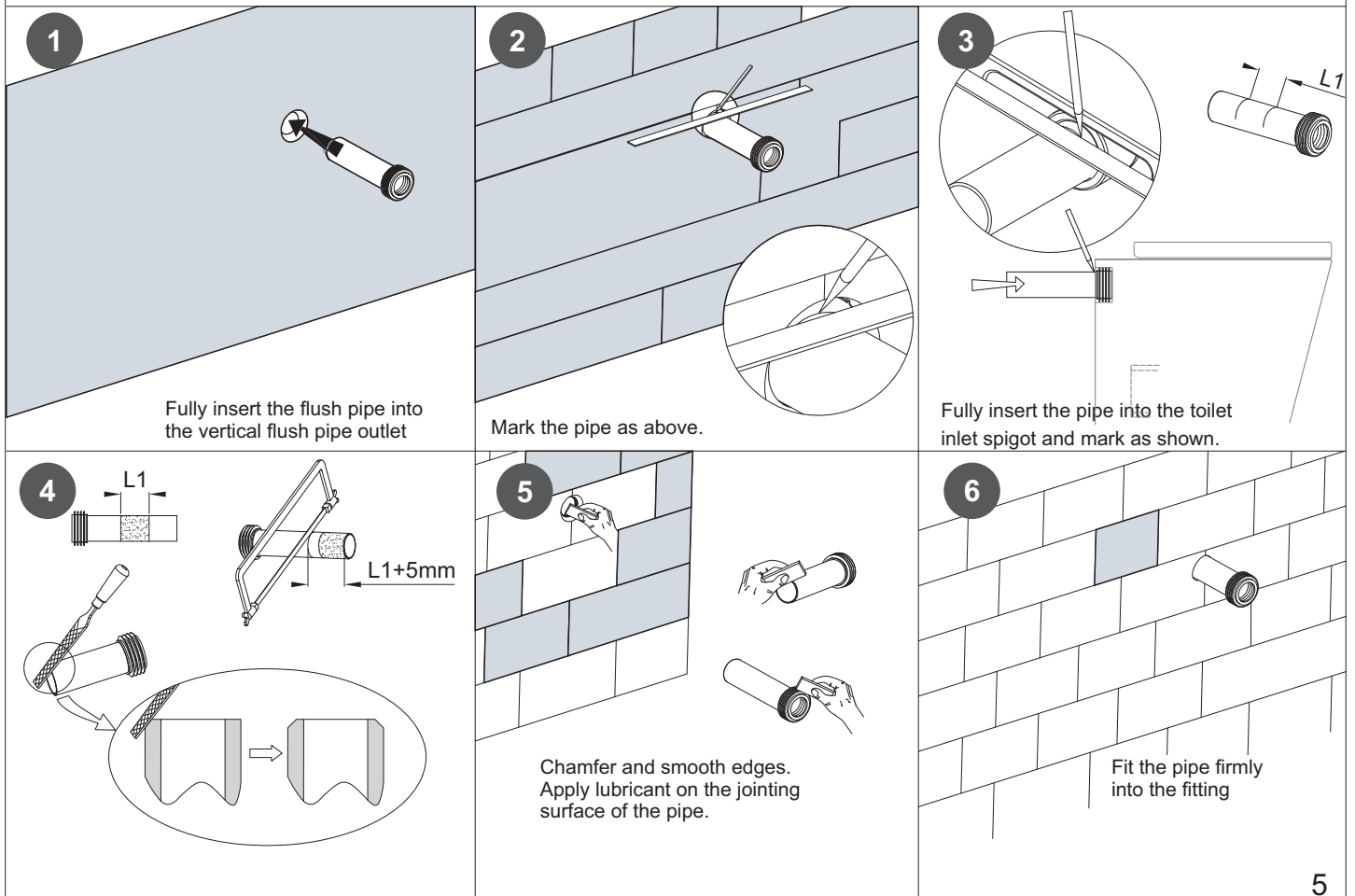

8. Actuator Installation

<p>1</p> <p>Cut and remove excess actuator box</p>	<p>2</p> <p>Remove and discard plate</p>	<p>3</p> <p>Separate fixing plate from assembly</p>
<p>4</p> <p>Install fixing plate</p>	<p>5</p> <p>"Click"</p>	<p>6</p> <p>Lock pins in place</p>
<p>7</p> <p>Full flush - clear air tube</p> <p>Half flush - black air tube</p>	<p>8</p> <p>Attach button assembly</p>	<p>9</p>

11. Adjusting and cleaning instructions

6

10. Inlet/Outlet valve mechanism assembly drawing:

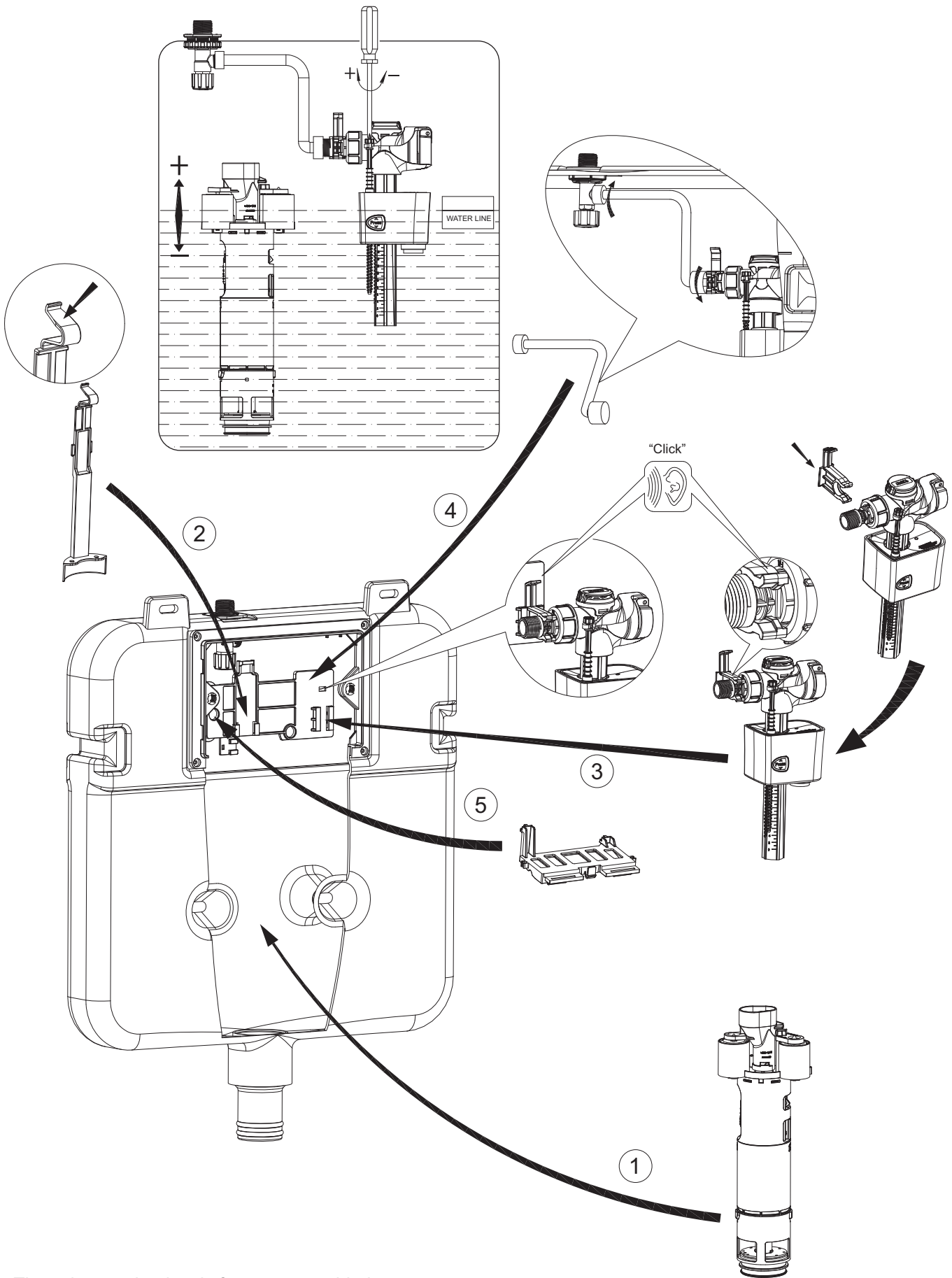

The valve mechanism is factory-assembled
This diagram is for reference only.